

# Top Pop Components



Base



One type 35in fully extended  
One type 22in fully extended.

2 each per kit



Pneumatic Cylinder 60.70 to 110.50mm, 30mm piston mounting base, rod eyelet, pin & clip.

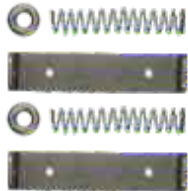

Latching rod, stop collar & return spring



2 each per kit



Left  
1 per kit

Right  
1 per kit

Pivots  
Universal mounting  
threaded for shoulder  
bolt and stud clip.  
1/4"x 20 Shoulder Bolt

2 per kit



90 degree  
1-threaded x poly tube

1 per kit



Air Fill  
1- Tire filler valve x Poly  
tube, threaded to mount  
with 2 washers & nut.

2 per kit



3 Way Tee  
3- Poly tube  
connections

1 per kit



Miniature Silencer  
Straight 1/4 x 18NPT  
1-threaded filter/ vent

2 per kit



Miniature Silencer  
Straight 1/8 Pipe Thread  
1-threaded filter/ vent

1 per kit



Air Line  
4.0 meters long  
Polyurethane Tube  
6.35mm x 4mm

# Top Pop Components

Top Pop™ is an on demand compressed air system. Air is pumped to lift at a preset time of 10 seconds. Solenoid built into handle dispenses air lowering Lid. Compressed air is not stored.

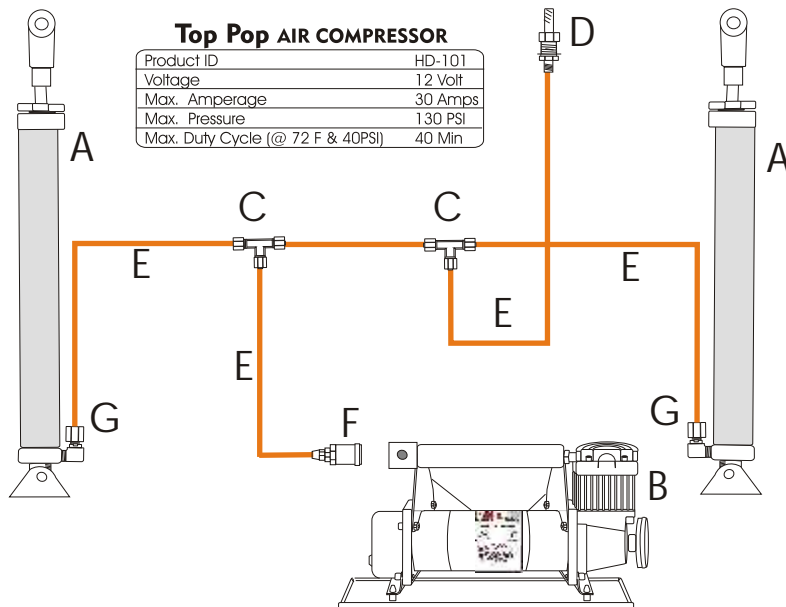

- A. Pneumatic cylinders left & right.
- B. 12 V DC Compressor & Controller
- C. 3 way Tee fitting.
- D. Air fill (Tire stem fill valve).
- E. Air lines.
- F. Air coupler to compressor.
- G. 90 degree fitting jetted to control air flow during down cycle.

Note: H Fitting is jetted. In the unlikely event of air line damage, the lowering of the LID is controlled.

**CAUTION: HOT**

Compressor and fittings can be very hot, use caution when handling.

**IMPORTANT:**  
This air compressor is equipped with THERMAL OVERLOAD PROTECTOR. Compressor will shut off automatically protecting motor from over heating. Turn off compressor and allow to cool (approx 30 minutes) before restarting.

Used with Top Pop™ Follow all instructions provided, leave start switch in the on position at all times.

## Electrical Schematic

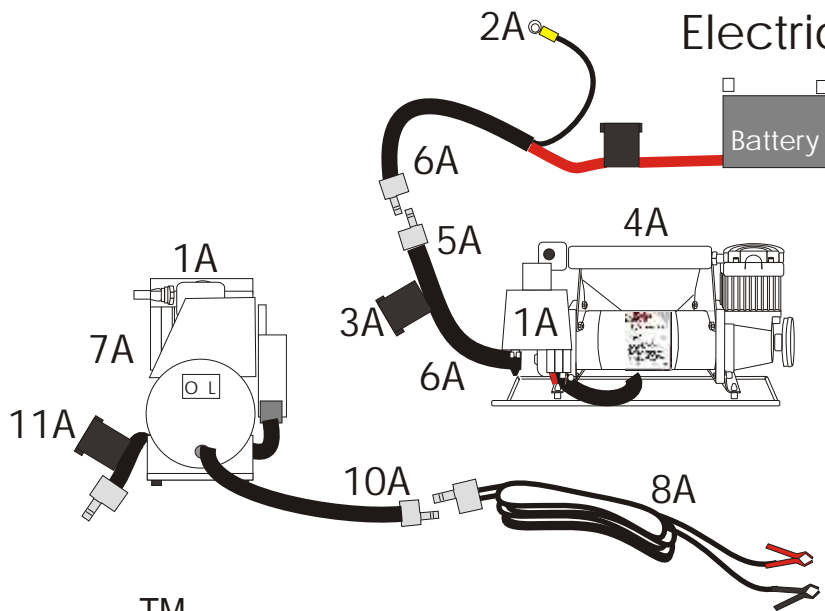

Top Pop™ is an air on demand system. Control wires 9A are input trigger wires and when used will start compressor or solenoid. Typically each control relay (10A) when activated will run for 10 sec. All lifting or lowering must be completed within this time.

- 1A. Keyless receiver and relay.
- 2A. Black wire chassis ground.
- 3A. Fuse 30 amp max
- 4A. Air compressor.
- 5A. Plug to keyless receiver relay.
- 6A. Plug to power source.
- 7A. End view on off switch of Comp.
- 8A. Battery clamp & cable
- 9A. Input trigger
- 10A. Direct compressor power feed.
- 11A. Relay Fuse 15 amp max.

**Top Pop™**  
Lifting compressor runs for adjustable 5 to 15 seconds in this time compressing enough air to lift nearly any Lid. A fail safe feature initiates if the air pressure exceeds 75 PSI fuse 11A will open (never exceed this recommend fuse size). Higher pressure can only be achieved when 10A is plugged into 8A to battery or other direct power supply.

# Top Pop Components

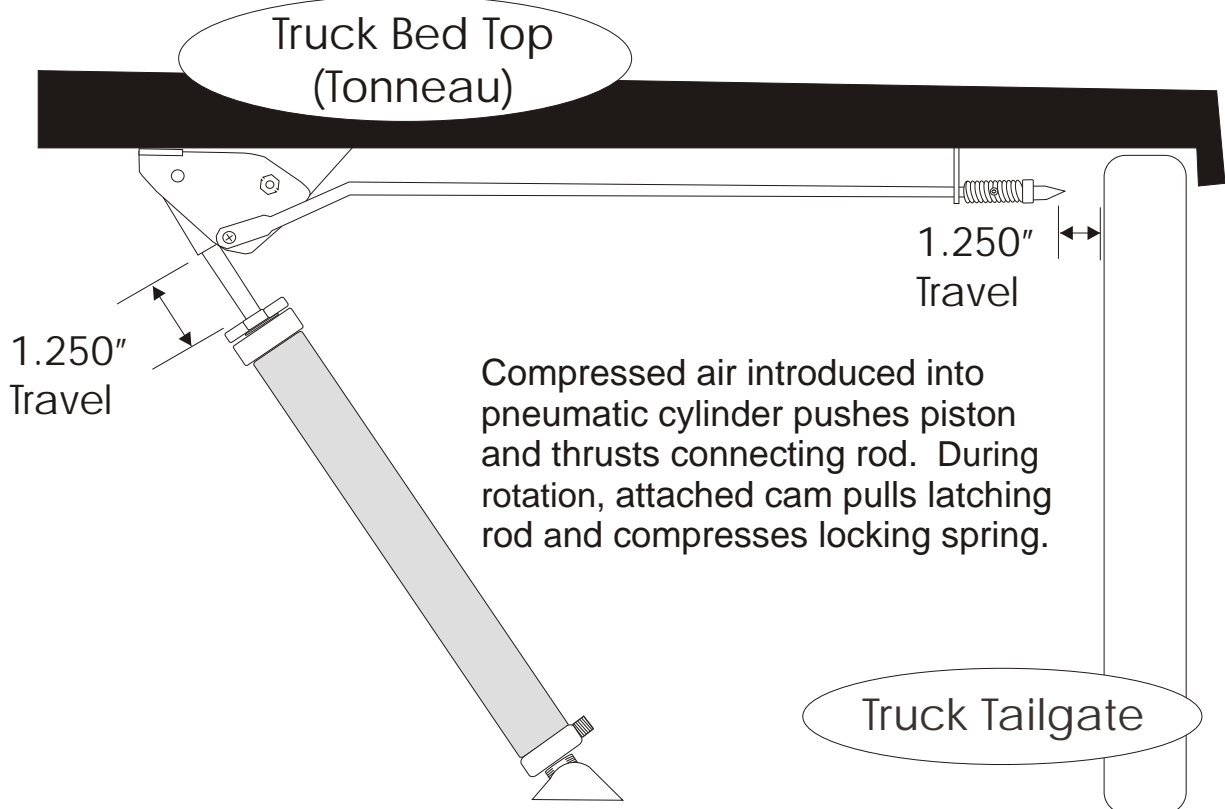
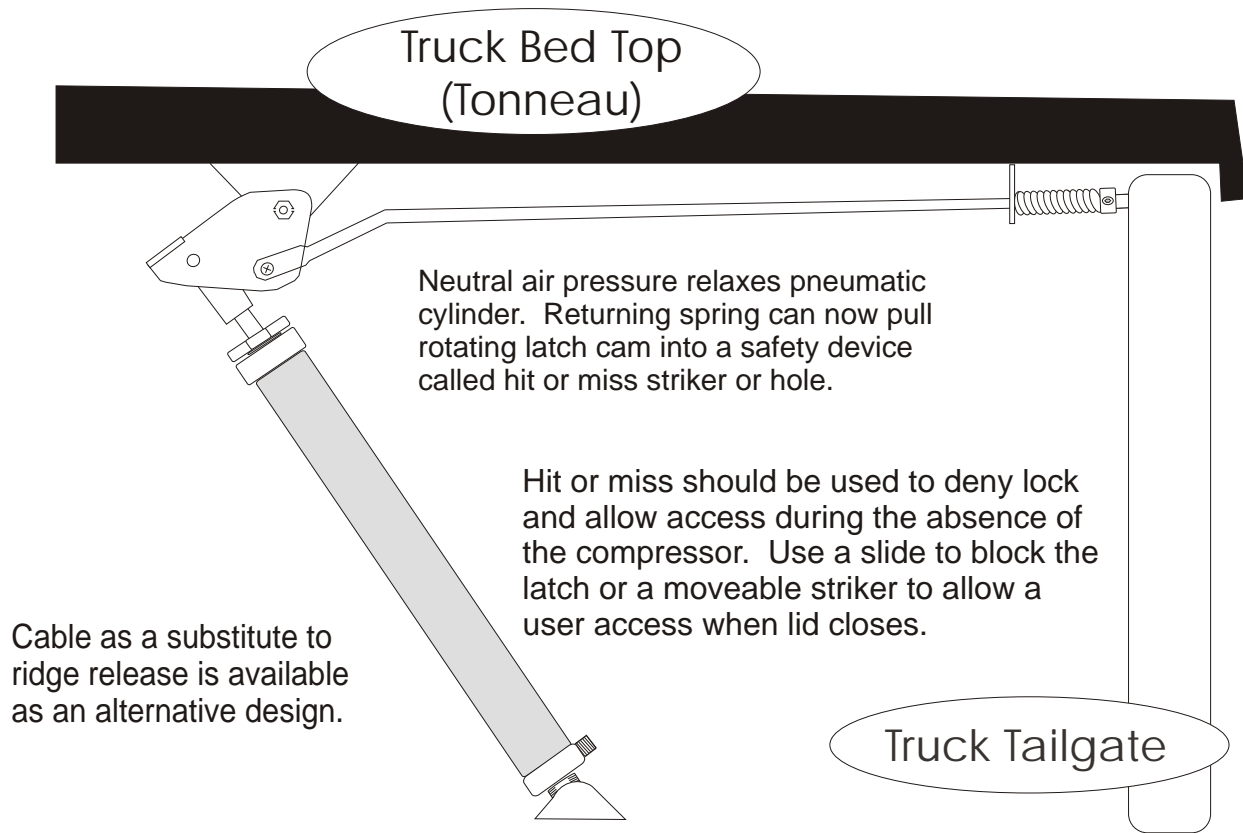

# Top Pop Parts Orientation

A. Controller is mounted on compressor, both are water resistant, installation should be where not over exposed.

B. Compressor: on/off switch should remain on at all times when compressor is being used to lift and lower. When compressor is off or disconnected all LIFTING functions are disabled.

Note: Use of a latching blocker prop are recommended when compressor is disconnected or off preventing unwanted locking (See latch block details).

C. Pneumatic override: Should be located in an accessible location. Air pumped into the tire stem valve will unlock latching system. Removing air from stem will likewise lower pneumatic lift and reset lock. Note: Damage to any air line will cause all pneumatic & override functions to become inoperable. Great care must be given when installing air lines. Grommets have sharp edges. Maintain safe distance from exhaust and prevent kinks and knots in air line that can prevent air flow.

D. Mounting Base & Pin: When using an existing gas lift mounting bracket, typically only the top mounting point can be used. The mounting base placement is critical and care should be given that the pneumatic cylinder doesn't bump the wheel well when in the closed position.

E. Pneumatic cylinder should be protected from impacts. Dents can cause non repairable damage to pneumatic rams.

F. Top of lifting rod connection: The latching pivot and locking rod is shown with the gas lifting connection point removed. The removed gas lift point on the lid becomes the pivoting point of the pivot.

G. Locking rod is pulled unlocked during lift, when air is dispensed returning the spring pushed locking rod and setting it to locked.

H. Tip of locking rod.

I. Locking rod return spring.

J. Pilot bracket will typically need to be custom fabricated and often epoxied to the lid being retrofitted.

## Load ID chart

70 lbs/40psi/5sec
78 lbs
85 lbs
91 lbs
100 lbs/60psi/10 Sec
107 lbs
114 lbs
121 lbs
128 lbs/85psi/15sec

100 pounds is Top Pop's ideal lifting weight. Higher weights would require user to depress fob for an additional cycle.

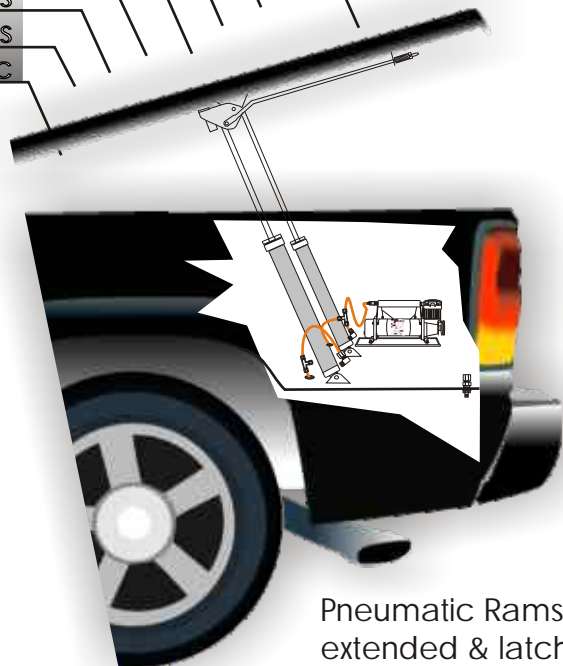

Pneumatic Rams extended & latch unlocked

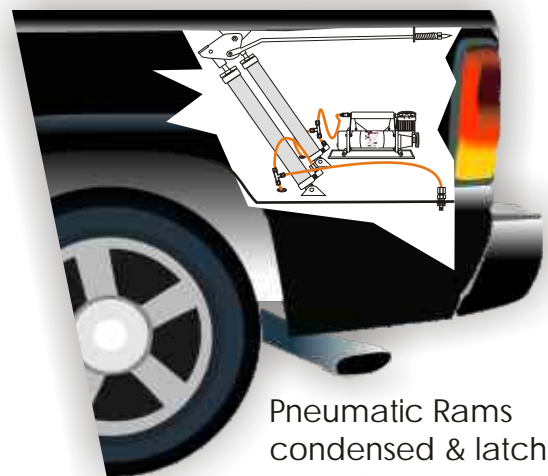

Pneumatic Rams condensed & latch locked.

# Code Learning & Configuration

## Instructions



Function	Pin#	Optional Harness
Lock Input	#3	Brown
Unlock Input	#2	Violet
Act Output	#1M	Blue
Act Output	#2M	Red
12vdc 20 amp	+	Red
Ground	-	Ground

### Code Learning:

A.) When the power is turned on, within 5 seconds, press button 1 and button 2 at the same time. The system will then enter the code learning mode. The UNLOCK OUTPUT will trigger to remind you that the system is in code learning mode.

B.) Within 5 seconds after entering the code learning mode, press any button on the transmitter. The UNLOCK OUTPUT will trigger to tell you the transmitter has been recognized and is compatible with the system. A maximum of 12 transmitters can be coded per system.

C.) During code learning, if there is no action after 5 seconds, the system will exit the code learning mode. The UNLOCK OUTPUT will be the reminder.

### Button Functions:

A.) Press button 1 to lock.

B.) Press button 2 to unlock.

### Input Signals: Default Negative

A.) #3 will input LOCK NEGATIVE/POSITIVE SIGNAL.

B.) #2 will input UNLOCK NEGATIVE/POSITIVE SIGNAL.

### Configuration Instructions:

The signals input can be changed from default negative to positive. The outer shell must be removed. Do this with the RC35a unplugged as shown below by removing the 2 prong jumper switch shown as FIG A. in RED.

Caution: Care Should be Taken As To Not Damage Inter Components.

### Dip Switch

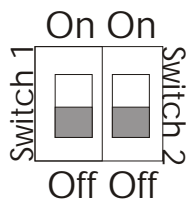

Out Put Timer Settings		
Switch 1	Switch 2	Output Time
On	On	0.5sec
On	Off	5.sec
Off	On	10. sec
Off	Off	15. sec

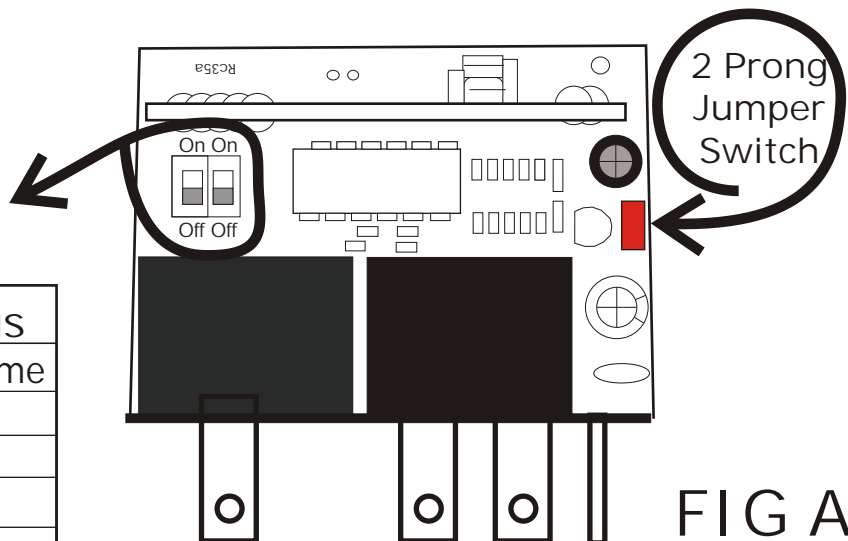

Optional

## Flex Switch I (RS1)

Mounting Flex Switch (RS1) is done using the 2 Fasteners through mounting holes. Carefully select the area best suited for its placement.

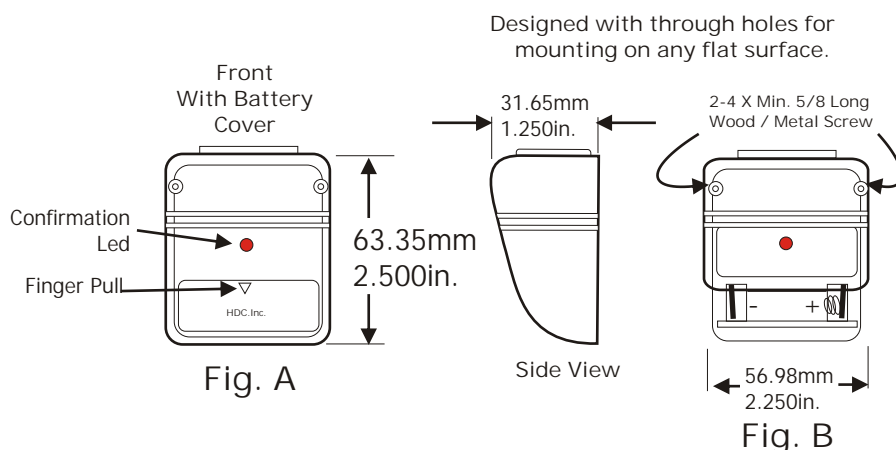

Flex Switch

is coded using the same process as Key Fobs described in User Manual code learning section.

## Flex Switch II (RS2)

Replacing the Flex Switch II battery the cover must be removed. Using only a fingernail or paper clip, depress the tab on the bottom of the flex switch. Cover will hinge at the top revealing the inside components. Replacement batteries are 12v part # GP23A, CN23A, E112 and Vr22 or similar class battery.

Replacement battery must be installed as shown in Fig B. Its orientation is specific to +- polarities clearly marked.

Replace cover and test.

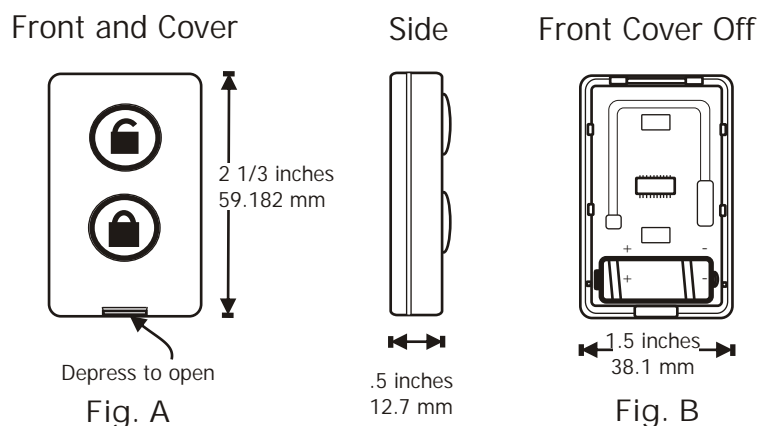

The battery mates to the contacts and cradles inside the bezel. Battery held in place only by cover and contacts.

## T-25 Transmitter

To replace the T-25 Key Fob battery (Fig D.), the shell of the transmitter must be removed. Pry between the depression around the shell and separate the fob into 2 pieces exposing the battery as shown in Fig. D. Replacement batteries are 12v part # GP23A, CN23A, EL12 and VR22 or similar class battery.

Replacement battery must be installed as shown in Fig. D. Its orientation is specific to - + polarities clearly marked. Replace cover and test.

When Needed Replacement Batteries Are Free To Original Owners Please Call HDC Inc.



Fig. C

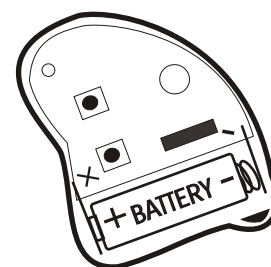

Fig. D  
Front With Cover Off