

FRONT
of Interior Latch
with Thumb Lock

**Magnified
View**

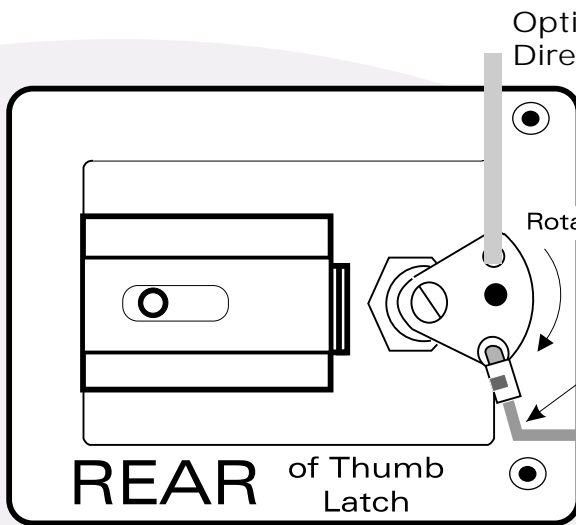
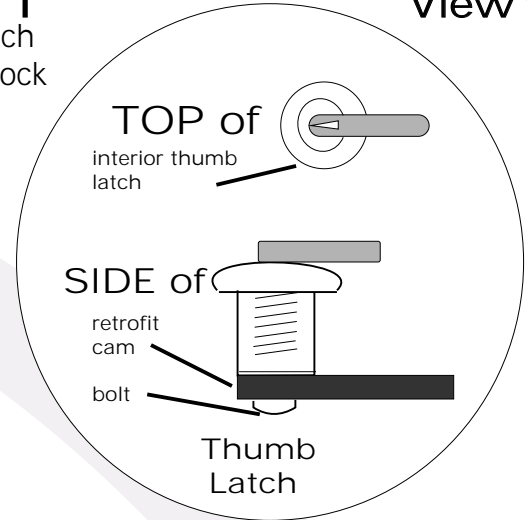

REAR of Thumb Latch

Optional
Direction

Rotation

Note: 70 to 90 degree
bend is necessary to
clear center pin when
rotated unlocked.

Linkage for this
application
must be custom
bent.

**SEE INSTRUCTIONS
FOR ADHESIVE BASE**

**SEE WIRING
INSTRUCTIONS**

Lock Replacement Recommendations

Remove existing cam on back of the thumb latch body. Install the provided **Replacement cam** as shown in the diagram. The linkage provided must be bent to the most desirable location for the power pack. The rod should never exceed 8" of length to assure the proper placement when vehicle is in motion. To prevent loosening of the nut that holds the lock body, a very small amount of rubberized silicone should be applied. The use of silicone lubrication is recommended.

Inside View of Outside Keyed Latch

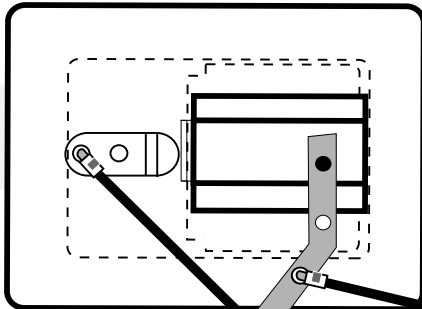

Paddle Latch Personnel Door Power Lock Installation

Inside View of Interior Door Paddle Latch (Shown With Manual Lock Release)

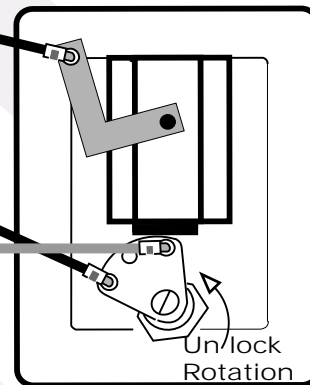

Optional Actuator Connection

SEE WIRING INSTRUCTIONS

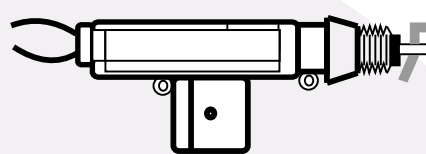

PLIII-O (CAB O.E.M.)

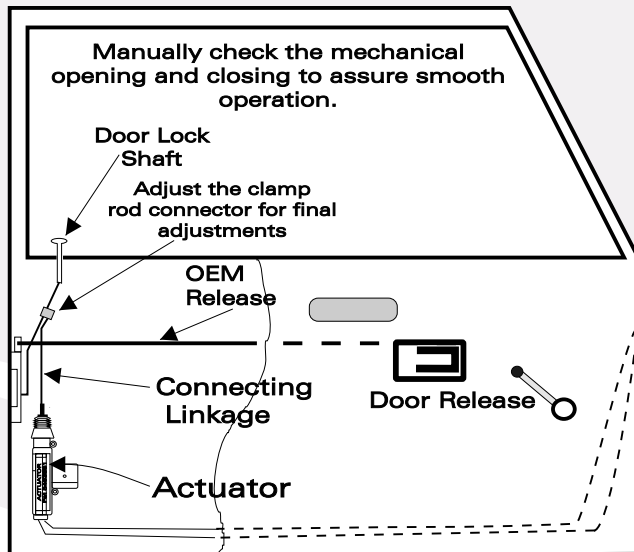

CAB DOOR RETROFIT

Installations using this system need to be carefully laid out prior to installing actuator. Be sure location will not interfere with window crank.

Wire exiting the door to the hinge pillar should have approx. 4" difference in the height to avoid damage to cable when door opens and closes. Recommend grommets and loom protector be used.

SEE WIRING INSTRUCTIONS